

BALCONIES

Installation guidelines for balustrade cladding

The following regulations and provisions must be observed when preparing and installing balustrade cladding using Trespa Meteon sheets:

- The applicable technical building regulations.
 - The German ETB directive 'Bauteile, die gegen Absturz sichern' (Building elements which protect against accidental falling). The various fixing options for Trespa have been tested with the applicable additional loads and stresses, in accordance with the German Einheitliche Technische Baubestimmungen (ETB - Uniform Technical Building Provisions) and in accordance with the latest technical developments. The results of these tests have been incorporated in the tables of dimensions.
 - When fixing Trespa as strips, the height of the strips must at least be equal to half the support distance.
 - Proof of stability must be submitted for balustrade structures of a drop height of 1 metre or more.
 - The standards and instructions for all parts of the balustrade structure and the anchoring facilities.
- When balustrade systems are used, the manufacturer's/ supplier's installation instructions also apply.
- Balustrade heights and maximum permissible openings in the cladding material in accordance with the provisions of the applicable national building regulations.
 - **Trespa Meteon panels must be installed such that they can still expand and contract.**

General installation guidelines

Joints

- Joint widths 2.5 mm per metre of panel length; and a minimum width of 10 mm for joints between two panels. If joint profiles are used, their body thickness must be considered as well.

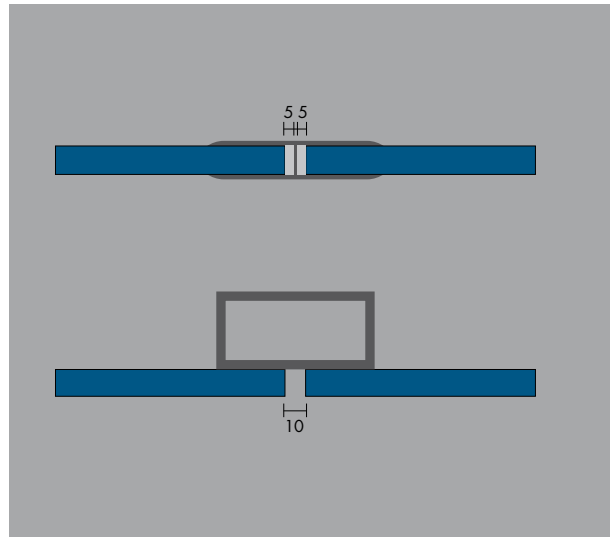

Fixing with blind rivets

Fixing with aluminium or stainless steel blind rivets; available with painted heads in all Trespa Meteon colours. Only stainless steel blind rivets must be used for steel subframes.

- **Suppliers:**
For local suppliers of fixings and fastenings please consult Trespa UK Ltd.
- **Blind rivet dimensions:**
Shank diameter = 5 mm.
Length = blind rivet package thickness + 5 mm (always at least 16 mm).
- **Head diameter:**
16 mm for blind rivets with painted heads.
- **Sliding points:**
Tighten the rivets using a special tool to keep them 0.3 mm free from the panel surface. Drill holes for sliding points using a stepped drill or a drilling template, so that the shank of the rivet is perfectly centred in the wider hole drilled. Note: use blind rivets and rivet tools of the same brand to ensure uniform dimensions.
- **Fixed point:**
Only one fixed point in the centre of the panel. Tighten the blind rivet on the fixed point without using the special tool. All other fixing points are sliding points.

Diameter of the hole	in the panel	in the subframe
Fixed point	5,1 mm	5,1 mm
Sliding point	10 mm	5,1 mm

- **Edge clearance of holes:**
At least 20 mm to the centre of the hole; maximum 20 x panel thickness.
- **The maximum permissible panel length is 3050 mm.**

Special tool

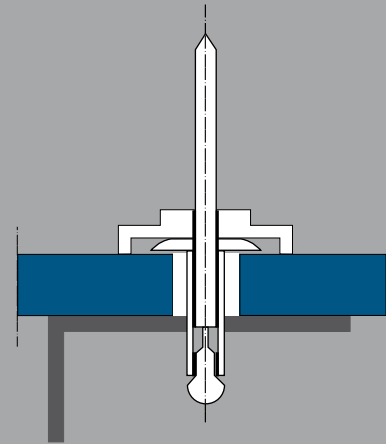

Sliding point

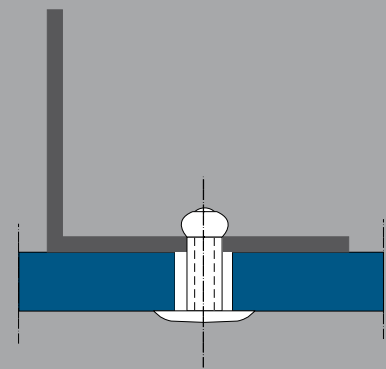

Fixed point

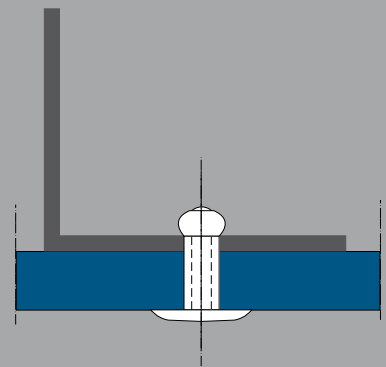

Drill template

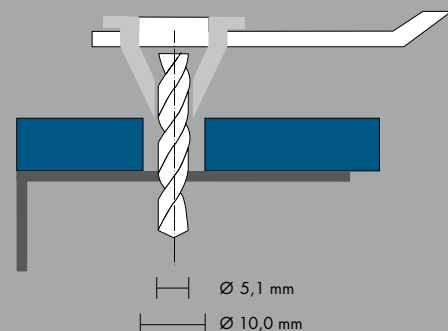

Fixing with balcony screws

Fixing with stainless steel balcony screws with painted heads or cup-shaped washers and plastic caps, available in all Trespa Meteon colours. Or fixing with special stainless steel fasteners for balcony panels and accompanying aluminium sleeves; the sleeves are coated and are also available in all Trespa Meteon colours. Both methods are suitable for panel thicknesses of 8 mm and up.

Balcony screws

- **Supplier:**
For local suppliers of fixings and fastenings please consult Trespa UK Ltd.
- **Screw dimensions:**
Diameter: 5 mm
Screw length: total material thickness + 10 mm
- **Head diameter:**
Screws with painted heads: 16 mm
- **Sliding and fixed points:**
One fixed point in the panel centre; otherwise only sliding points.

Diameter of the hole	in the panel	in the subframe
Sliding point		
Screws with cover caps	5,1 mm	10 mm
Screws with painted heads	10 mm	5,1 mm
Fixed point	5,1 mm	5,1 mm

Balcony screws & balcony panel fasteners

- **Supplier:**
For local suppliers of fixings and fastenings please consult Trespa UK Ltd.
- **Screw dimensions:**
Diameter: 5 mm
Length: at least total thickness of material package + 1 mm
Head diameter: 12 mm
- **Sleeve dimensions:**
Diameter: 10 mm; head diameter: 16 mm
- **Sliding and fixed points:**
One fixed point in the panel centre; otherwise only sliding points.

Sliding points

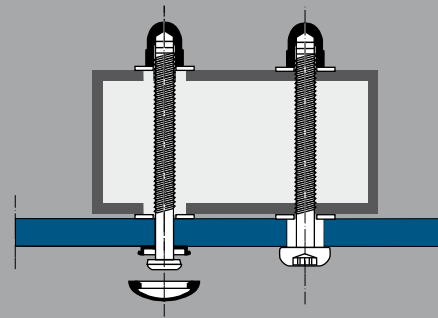

Fixed point

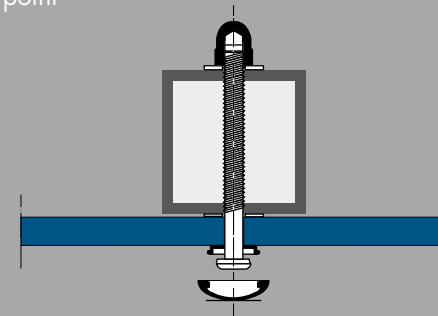

Sliding point

Fixed point

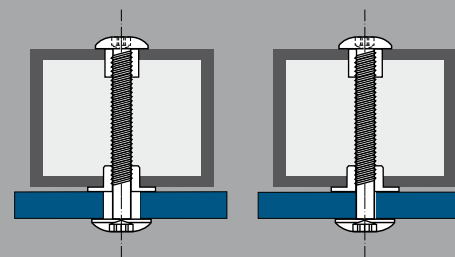

Diameter of the hole	in the panel	in the subframe
Sliding point	10 mm	10 mm
Fixed point	5,1 mm	10 mm

- **Edge clearance of holes:**
At least 20 mm to the centre of the hole
Maximum 20 x panel thickness
- **The maximum permissible panel length is 3050 mm.**

Fixing with clamps/welded metal lugs

Fixing with clamps

Clamps are used for panel thicknesses of 8 mm and up.

- Clamps are screwed to the horizontal rails or vertical battens.
- If the clamps are fixed to vertical battens, each panel has to be secured to prevent it from sliding out of position, for example by means of lock pins.
- Minimum clamp depth 35 mm.
- Adjust the distance between the clamp parts to the panel thickness taking into account dimensional tolerances and fixed EPDM gaskets.
- Leave minimum 2.5 mm/m free space between the clamp and the edge of the panel.
- **Sliding points:**
Sliding points are slotted holes in the section.
- **Fixed point:**
Only one fixed point in the centre of the panel;
hole diameter = screw diameter.
All other fixing points are sliding points.
- **Edge clearance for clamps:**
maximum 20 x panel thickness.
- **Suppliers:**
For local suppliers of fixings and fastenings please consult Trespa UK Ltd.

Fixing using welded metal lugs

Welded metal lugs can be used for panel thicknesses of 8 mm and up.

- Metal lugs are welded to the horizontal rails or vertical battens.
- Leave minimum 2.5 mm/m free space between the clamp and the edge of the panel.
- **Sliding points:**
Diameter of the holes in the welded metal lugs = screw diameter + 5 mm = 10 mm (for a screw diameter of 5 mm).
- **Fixed point:**
Only one fixed point in the centre of the panel;
hole diameter = screw diameter.
All other fixing points are sliding points.
- **Edge clearance of holes:**
at least 20 mm;
maximum 20 x panel thickness.

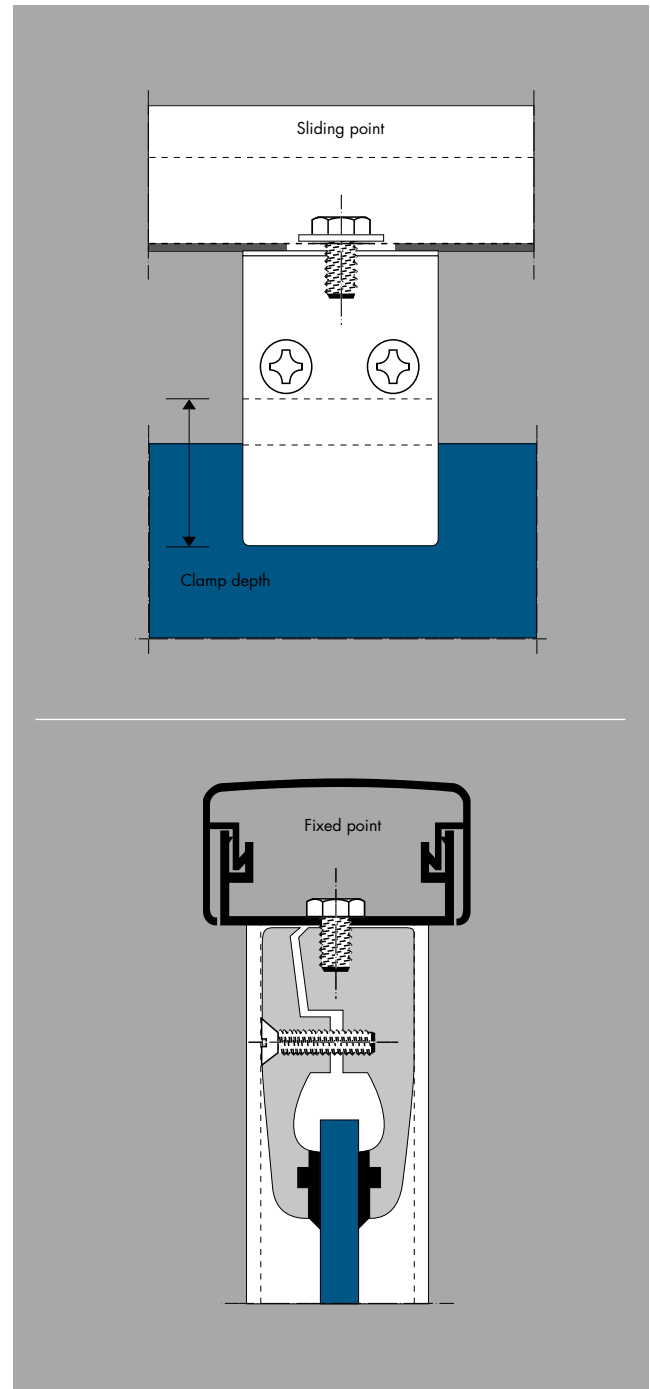

Maximum spans and fixing centres for panels only secured via fixing points on the edges

Panel thickness (mm)	Fixing	Fixing centre (mm)
8	Blind rivet	A = 500
	Screw	A = 600
	Clamp or welded metal lug	A = 600
		L = 750
10	Blind rivet	A = 500
	Screw	A = 750
	Clamp or welded metal lug	A = 750
		L = 950
13	Blind rivet	A = 500
	Screw	A = 1000
	Clamp or welded metal lug	A = 1000
		L = 1250

A = Screw / blind rivet / welded metal lug or clamp distance

L = Panel span; distance to the centre of the carrier profile (or strip) to the centre of the carrier profile (or strip)

Only secure on the edges

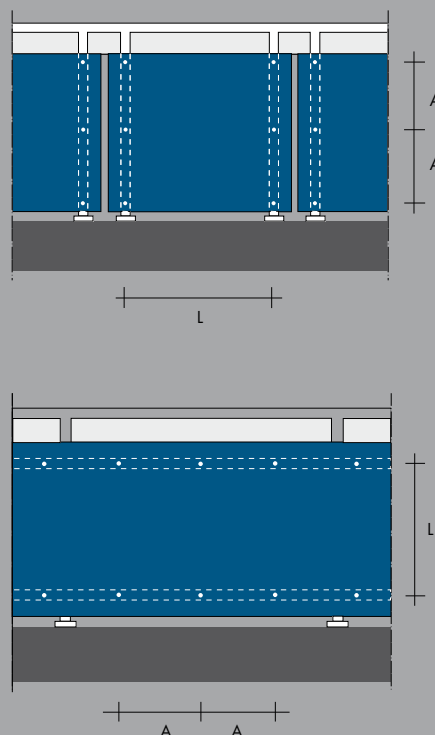

Clamps or welded metal lugs

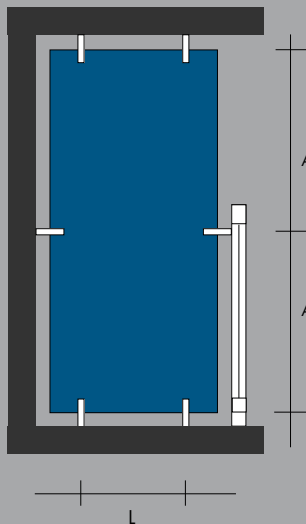

Maximum spans and fixing centres for panels secured via fixing points on the edges and in the centre

Panel thickness (mm)	Fixing	Fixing centre (mm)
8	Blind rivet	A = 600
	Screw	A = 800 L = 950
10	Blind rivet	A = 600
	Screw	A = 1200 L = 1200
13	Blind rivet	A = 600
	Screw	A = 1500 L = 1500

A = Screw/rivet distance

L = Panel span; distance from the centre of the carrier profile (or strip) to the centre of the carrier profile (or strip)

For aesthetical reasons we recommend decreasing the fixing centres and panel spans listed by 5 to 10% for building heights of over 8 metres. We recommend decreasing these values by 10 to 15% for building heights of over 20 metres and that no 6-mm panels are used in this case.

Secured both on the edges and in the centre

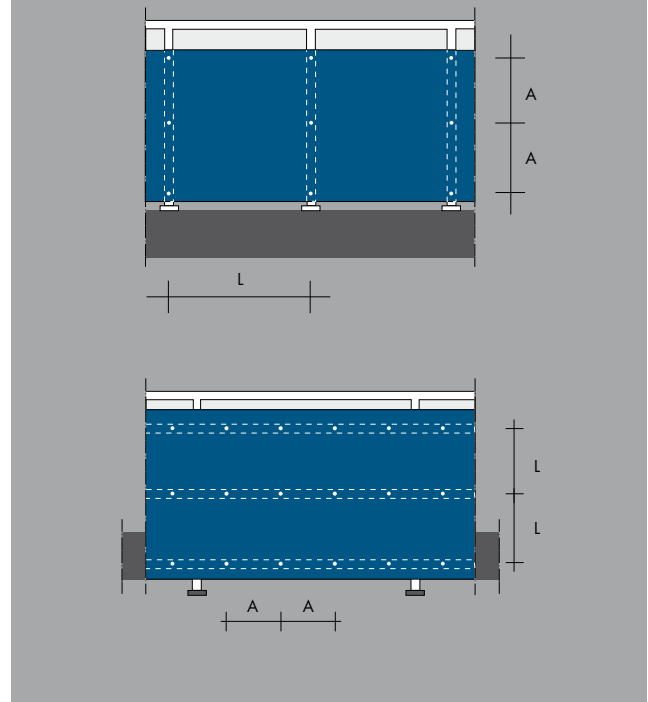

Fixing with profiles

Trespa Meteon panels of panel thicknesses of 6 mm and up can be fixed with profiles on two or four panel sides. The profiles must offer static bearing support in a longitudinal direction.

▪ Profiles:

The profile dimensions must be adjusted to the panel thickness, taking into account dimensional tolerances and fixed EPDM gaskets.

- **Depth of groove in panel: minimum 20 mm.**
- Keep the edges of the panel at least 6 mm free from the profiles on three sides, enabling the panel to expand and contract.
- **Water drains:**
Water drains in lower horizontal rail by fitting slotted holes of 5 x 25 mm or drilling holes with an 8-mm diameter. Install two supports (minimum 5 x 50 mm) in the lower profile for every panel.
- For optical reasons a metal H-section is to be used where two panels meet.

Maximum panel spans and fixing centres for panels fixed on two sides

Panel thickness (mm)	Span L (mm)
8	750
10	950

L = Maximum panel span in mm

For aesthetical reasons we recommend decreasing the fixing centres and panel spans listed by 5 to 10% for building heights of over 8 metres. We recommend decreasing these values by 10 to 15% for building heights of over 20 metres and that no 6-mm panels are used in this case.

Fixing detail

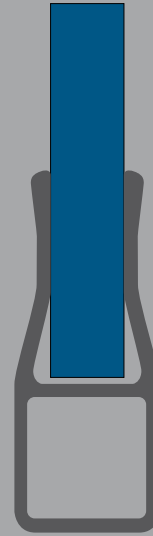

Fixing detail

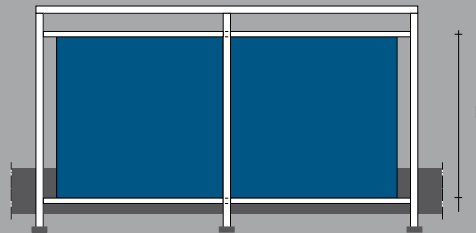

Maximum spans and fixing centres for panels fixed on four sides

L = always the short panel side in mm

A = always the long panel side in mm

For aesthetic reasons we recommend decreasing the fixing centres and panel spans listed by 5 to 10% for building heights of over 8 metres. We recommend decreasing these values by 10 to 15% for building heights of over 20 metres and that no 6-mm panels are used in this case.

